

Recovering Performance Loss Due to Air Binding – A Case Study –

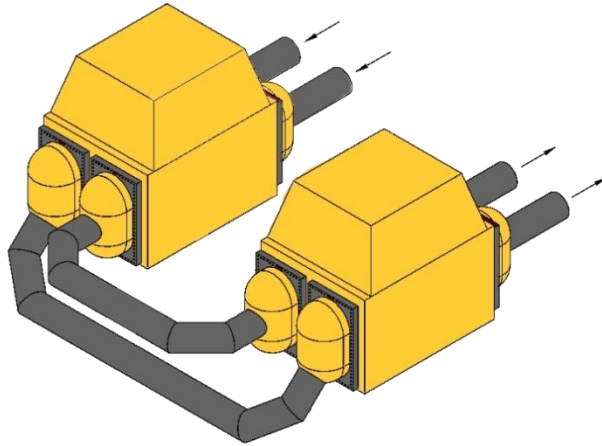

In 2007 Intek was presented with an opportunity to study an underperforming Ingersoll Rand condenser, and plan a program for increasing performance via engineered retrofit. The primary objectives for the condenser study were to find a means to mitigate ongoing load limiting conditions in the summer time due to high condenser pressure and to improve chronic poor condenser performance, which had continued despite maintaining excellent tube cleanliness with an online ball cleaning system.

An extended outage was planned for 2010 to install an HP turbine dense pack and perform a condenser retube due to wall thickness deterioration of Cu:Ni 90:10 tubes. This outage schedule provided an opportunity to implement a condenser retrofit to improve thermal performance.

The first objective of the engineering study phase was to determine the magnitude of low condenser performance and also identify the root causes for the specific degradation mechanisms. The results of the initial study verified that the ball cleaning system was maintaining clean tube conditions and that air binding, despite low air in-leakage, was the overwhelming cause for the measured poor performance. Following the engineering study a proposal was accepted to alter the steam, condensate and noncondensable flows by installing a steam side condenser retrofit concurrent with the condenser retube. A comparison of the measured condenser pressures (5 minute averages) before (5 years prior) and after the condenser retrofit for the same condenser duty range is plotted in the figure below.

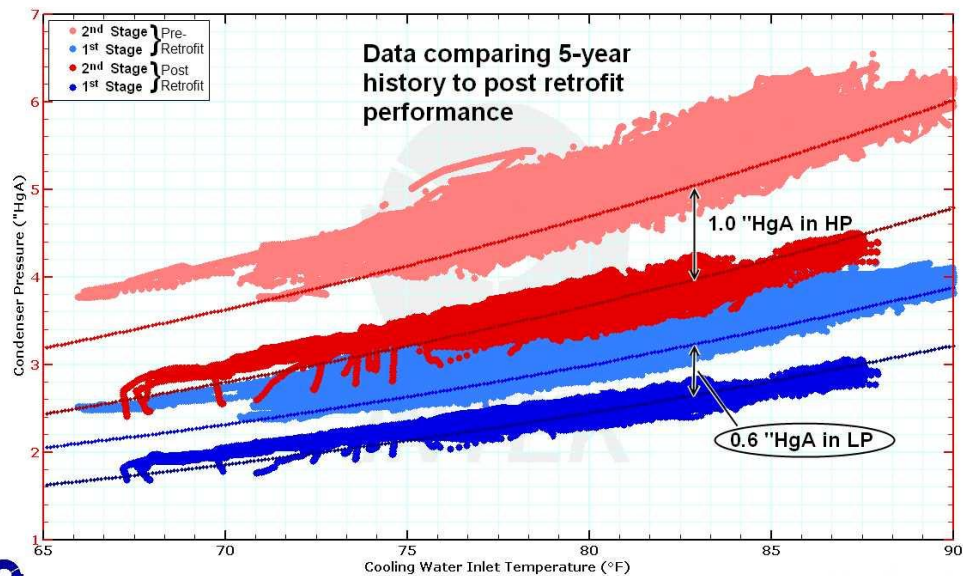

Intek, Inc.
751 Intek Way
Westerville, OH 43082
Ph: (614) 895-0301
sales@IntekFlow.com
www.IntekFlow.com

